

TP100, TP500 General Purpose Accelerometer

Datasheet

Bently Nevada Machinery Condition Monitoring

161M1037 Rev. -

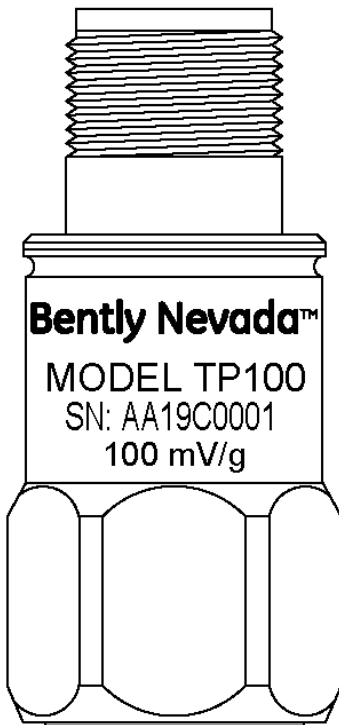

Description

The accelerometers in this sensor series offer a number of features making them well suited for harsh industrial environments and installation in locations with limited available space. These case-mounted accelerometers provide acceleration measurements in units of g or m/s².

The sensor has a standardized output voltage proportional to the level of acceleration which can interface to a variety of condition monitoring solutions. The range of vibration frequencies detected by these sensors spans from 0.2 – 14,000 Hz.

Features

- Rugged design
- Corrosion resistant
- Hermetic seal
- Case isolated

Benefits

- Clear signals at low vibration levels
- Extended low end frequency response
- Improved signal-to-noise ratio vs. other general purpose accelerometers
- A single sensor can detect both low- and high-speed vibrations
- Optimized for monitoring slow-turning machinery such as cooling tower fans and slow-speed gearboxes



TP100 Specifications

Parameters are specified from +20 °C to +30 °C (+68 °F to +86 °F) and at 100 Hz unless otherwise indicated.

Dynamic

Sensitivity ± 5% 25°C		100 mV/g
Acceleration range		80 g peak
Amplitude non-linearity		1%
Frequency response	± 5%	3 - 5,000 Hz
	± 10%	1 - 9,000 Hz
	± 3 dB	0.5 - 14K Hz
Resonance frequency		30 kHz
Transverse sensitivity, maximum		5% of axial
Temperature response	-55°C	-20%
	+120°C	+10%

Electrical

Power requirement (IEPE)	Excitation voltage	18 - 30 VDC
	Regulated current	2 - 10 mA
Electrical noise, equivalent g: (Frequency response, spectral noise and broadband noise values are typical.)		
Broadband	2.5 Hz to 25 kHz.	700 µg/√Hz
Spectral	10 Hz	10 µg/√Hz
	100 Hz	5 µg/√Hz
	1,000 Hz	5 µg/√Hz
Output impedance, maximum		100 Ω
Bias output voltage		12 Vdc ± 10%

Grounding

case isolated, internally shielded

Environmental

Temperature range	-55° to +120°C
Vibration limit	500 g pk
Shock limit.	5,000 g pk
Electromagnetic sensitivity, equiv. g, maximum	70 µg/gauss
Sealing	hermetic
Base strain sensitivity, maximum	0.0002 g/µstrain

Physical

Sensing element design	PZT, shear
Dimensions	See Graphs and Figures on page 7.
Weight	90 grams
Case material	316L steel, stainless
Mounting	1/4-28 UNF tapped hole
Connector	2-pin, MIL-C-5015
Recommended cabling	shielded, twisted pair
Recommended cable length (assuming max vibration of 50g, frequency 12 kHz, and cable capacitance 60 pf/ft.) For longer lengths, contact Bently Nevada Tech Support .	99 ft

TP500 Specifications

Parameters are specified from +20 °C to +30 °C (+68 °F to +86 °F) and at 100 Hz unless otherwise indicated.

Dynamic

Sensitivity, ± 5%, 25°C		500 mV/g
Acceleration range		10 g peak
Amplitude non-linearity		1%
Frequency response	± 5%	0.7 - 5K Hz
	± 10%	0.5 - 9K Hz
	± 3 dB	0.2 - 14K Hz
Resonance frequency		30 kHz
Transverse sensitivity, maximum		5% of axial
Temperature response	-55°C	-7.5%
	+120°C	+7.5%

Electrical

Power requirement	Voltage source	18 - 30 VDC
	Current regulating diode	2 - 10 mA

Electrical noise, equivalent g: (Frequency response, spectral noise and broadband noise values are typical.)

Broadband	2.5 Hz to 25 kHz.	250 µg/√Hz
Spectral	10 Hz	2.5 µg/√Hz
	100 Hz	1.5 µg/√Hz
	1,000 Hz	1.5 µg/√Hz
Output impedance, maximum		100 Ω
Bias output voltage		12 Vdc

Grounding	case isolated, internally shielded
-----------	------------------------------------

Environmental

Temperature range	-55° to +120°C
Vibration limit	500 g pk
Shock limit.	5,000 gpk
Electromagnetic sensitivity, equiv. g, maximum	70 µg/gauss
Sealing	hermetic
Base strain sensitivity, maximum	0.0002 g/µstrain

Physical

Sensing element design	PZT, shear
Dimensions	See Graphs and Figures on page 7.
Weight	90 grams
Case material	316L steel, stainless
Mounting	1/4-28 UNF tapped hole
Connector	2-pin, MIL-C-5015
Recommended cabling	shielded, twisted pair
Recommended cable length (assuming max vibration of 50g, frequency 12 kHz, and cable capacitance 60 pf/ft.) For longer lengths, contact Bently Nevada Tech Support.	99 ft

Connections

Function	Connector pin
Power/signal	A
Common	B
Ground	shell

Compliance and Certifications

FCC

This device complies with part 15 of the FCC Rules. Operation is subject to the following two conditions:

1. This device may not cause harmful interference.
2. This device must accept any interference received, including interference that may cause undesired operation.

EMC

EN 61000-6-2

EN 61000-6-4

EN 61326-1

EN 61326-2-3

EMC Directive 2014/30/EU

Electrical Safety

EN 61010-1

LV Directive 2014/35/EU

Ordering Information



For the detailed listing of country and product specific approvals, refer to the *Approvals Quick Reference Guide* (108M1756) available from Bently.com.

General Purpose Accelerometer TP100 and TP500

TP100	1/4-28 to 1/4-28 and 1/4-28 to M8 mounting studs and box supplied. Includes calibration data.
TP500	No mounting stud supplied. Includes calibration data.

Interconnection Cables

9571	Cable with 2-pin straight connector
84661	Cable with 2-pin straight connector with armor
89477	Cable with 2-pin 90 degree connector

Standard Cable Lengths

Feet	Meters (approximate)
6 ft	1.8 m
8 ft	2.4 m
10 ft	3.0 m
12 ft	3.6 m
15 ft	4.5 m

Feet	Meters (approximate)
17 ft	5.0 m
20 ft	6.0 m
25 ft	7.6 m
30 ft	9.0 m
33 ft	10.0 m
50 ft	15.2 m
99 ft	30.0 m

Custom Cable Part Numbers

You can order custom cable lengths in increments of 1.0 ft (305 mm) at additional cost. Some cables have a minimum and maximum length.



Use 'NN' in these part numbers to specify the length (in feet) of the cable you want to order.

Part Number	Description
9571-NN	Two-conductor twisted, shielded 22 AWG cable with two-socket moisture-resistant female connector at one end, terminal lugs at the other end. Used with monitors. Not for use with 21128 Velocity Transducer Housing. Min. length: 2.0 ft (0.6 m) Max. length: 99 ft (30 m)
84661-NN	Two-conductor twisted, shielded 22 AWG armored cable with two-socket moisture-resistant female connector at one end, terminal lugs at the other end. Used with monitors. Not for use with 21128 Velocity Transducer Housing. Min. length: 3.0 ft (0.9 m)

Part Number	Description
	Max. length: 96 ft (29 m)
106765-NN	Two-conductor 22 AWG twisted, shielded cable with two-socket plug and fluorosilicone elastomer boot at one end, terminal lugs at the other. Used with monitors. Not for use with 21128 Velocity Transducer Housing. Min. length: 2.0 ft (0.6 m) Max. length: 99 ft (30 m) Order in Increments of 3 meters.

Graphs and Figures

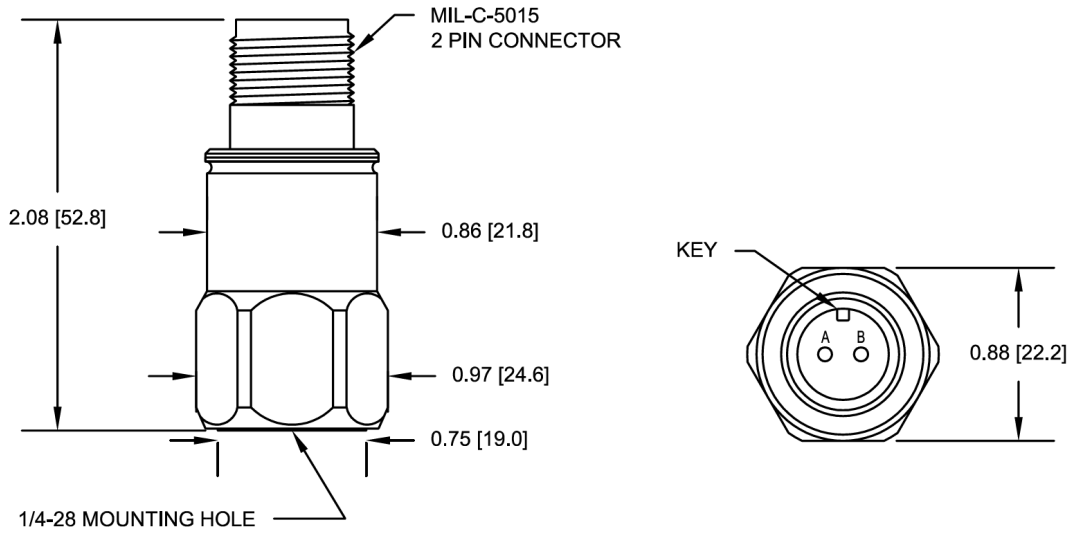

Figure 1: TP100 and TP500 Transducer

Dimensions in inches (mm)

Copyright 2021 Baker Hughes Company. All rights reserved.



Bently Nevada and Orbit Logo are registered trademarks of Bently Nevada, a Baker Hughes Business, in the United States and other countries. The Baker Hughes logo is a trademark of Baker Hughes Company. All other product and company names are trademarks of their respective holders. Use of the trademarks does not imply any affiliation with or endorsement by the respective holders.

Baker Hughes provides this information on an "as is" basis for general information purposes. Baker Hughes does not make any representation as to the accuracy or completeness of the information and makes no warranties of any kind, specific, implied or oral, to the fullest extent permissible by law, including those of merchantability and fitness for a particular purpose or use. Baker Hughes hereby disclaims any and all liability for any direct, indirect, consequential or special damages, claims for lost profits, or third party claims arising from the use of the information, whether a claim is asserted in contract, tort, or otherwise. Baker Hughes reserves the right to make changes in specifications and features shown herein, or discontinue the product described at any time without notice or obligation. Contact your Baker Hughes representative for the most current information.

The information contained in this document is the property of Baker Hughes and its affiliates; and is subject to change without prior notice. It is being supplied as a service to our customers and may not be altered or its content repackaged without the express written consent of Baker Hughes. This product or associated products may be covered by one or more patents. See [Bentley.com/legal](https://www.bentley.com/legal).

1631 Bently Parkway South, Minden, Nevada USA 89423
Phone: 1.775.782.3611 (US) or [Bentley.com/support](https://www.bentley.com/support)
[Bentley.com](https://www.bentley.com)