

Company: Joyoung International Trading Co., Limited

Atten: Smiling

Mobile/WhatsApp: +86 18050035902

E-mail: [info@htechplc.com](mailto:info@htechplc.com)

Website: <https://www.joyoungintl.com/>

# Operation Manual

Bently Nevada™ Asset Condition Monitoring



## TK-3 Proximity System Test Kit



imagination at work

Part Number 177740-01  
Rev. NC (06/07)

**Copyright 2007. Bently Nevada LLC.  
All rights reserved.**

The information contained in this document is subject to change without notice.

The following are trademarks of General Electric Company in the United States and other countries:

Bently Nevada, Proximitor, Keyphasor

## **Contact Information**

The following contact information is provided for those times when you cannot contact your local representative:

---

Mailing Address	1631 Bently Parkway South Minden, Nevada USA 89423 USA
Telephone	1.775.782.3611 1.800.227.5514
Fax	1.775.215.2855
Internet	<a href="http://www.ge-energy.com/bently">www.ge-energy.com/bently</a>

---

---

## Additional Information

---

### Product Disposal Statement

Customers and third parties, who are not member states of the European Union, who are in control of the product at the end of its life or at the end of its use, are solely responsible for the proper disposal of the product. No person, firm, corporation, association or agency that is in control of product shall dispose of it in a manner that is in violation of any applicable federal, state, local or international law. Bently Nevada LLC is not responsible for the disposal of the product at the end of its life or at the end of its use.

# Contents

---

<b>1.</b>	<b>General Description.....</b>	<b>1</b>
<b>2.</b>	<b>Operation.....</b>	<b>5</b>
2.1	General.....	5
2.1.1	Spindle Micrometer Operation.....	9
2.1.2	Swing Arm Assembly Operation .....	12
2.1.3	Stop Cam .....	15
2.1.4	Keyphasor Input Operation.....	15
2.2	Power-Up and Adjustment.....	17
2.2.1	TK-3e.....	18
2.2.2	TK-3g.....	19
2.3	Observed Material Substitution.....	21
<b>3.</b>	<b>Maintenance .....</b>	<b>27</b>
3.1	General Maintenance.....	27
3.2	Wobble Plate .....	27
3.2.1	Stop Cam Adjustment.....	27
<b>4.</b>	<b>Calibration .....</b>	<b>33</b>
4.1	General.....	33
4.2	Transducer System Check .....	33
4.3	RV Monitor Check.....	35
4.4	TK-3 Monitor RV Calibration Check.....	36
4.5	Thrust Monitor Check.....	39
4.6	KPH Probe Gap Determination .....	39
<b>5.</b>	<b>Specifications.....</b>	<b>41</b>
5.1	Power.....	41
5.1.1	TK-3e.....	41
5.1.2	TK-3g.....	41
5.2	Housing.....	41
5.3	Dimensions (overall).....	41

---

5.4	Controls .....	42
5.5	Target Material.....	42
5.6	Wobble Plate.....	42
5.6.1	TK-3e Rotational Speed .....	42
5.6.2	TK-3g Rotational Speed .....	42
5.6.3	Vibration Amplitude Range .....	42
5.6.4	Target Button and Wobble Plate Interchangeability.....	42
5.7	Spindle Micrometer.....	42
5.8	Environmental .....	43
5.8.1	Temperature Range Operational .....	43
5.8.2	Exposure .....	43

## 1. General Description

---

The Bently Nevada Asset Condition Monitoring TK-3 Calibration Instrument (Figure 1-1 and Figure 1-2) provides a reference mechanical motion for performing field functional tests of machinery protection systems. The two TK-3 models have identical functions, but different power sources. The TK-3e is electrically powered, where the TK-3g is powered by pressurized air. Each model is available in English or Metric measurement versions.

The instrument includes two basic test devices: a Wobble Plate (which is used in conjunction with an oscilloscope) and a spindle micrometer. Both have a 4140 Series steel target, which the user can remove and replace with a material identical to that in the observed shaft.

<b>NOTE</b>
Bently Nevada probes and Proximitors® sensors operate on the eddy current principle. This requires that the target material used by the instrument is the same as the observed surface of the shaft. This ensures accurate calibration and functional testing.

Metals such as 1000 through 4000 Series steel will each present a response curve that is similar to the one for the 4140 Series steel. However, copper, aluminum, brass, titanium, and other types of metals used in the observed surface will require that you use a target of the same material. We stock many types of metal targets. Check with your Sales

or Service representative if you have special target requirements.

The spindle micrometer is used to check the voltage versus distance characteristics of the probe and Proximitor. You can also use the micrometer to calibrate thrust position.

The Wobble Plate generates vibration and Keyphasor® reference signals. A manually operated swing arm assembly controls the peak-to-peak vibration level by positioning the probe at the desired vibration level. The Speed Control Knob adjusts the rotational speed of the Wobble Plate.

If a probe has been permanently installed in a machine or is otherwise inaccessible, you can substitute a probe with the same part number for test purposes.

You can check a complete monitoring system by applying a mechanical input to the system probe and observing the meter indication, or by measuring the monitor output.

### **APPLICATION ALERT**

Use of this product in a manner not specified by the instructions presented in this manual could result in protection impairment and damage to the unit. Please follow all instructions carefully.

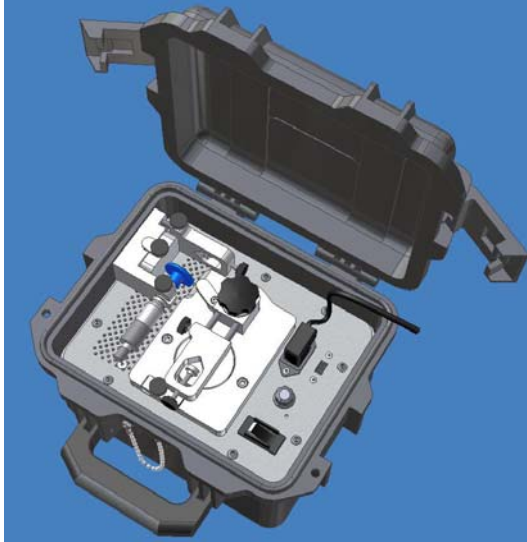

**Figure 1-1: TK-3e Overall View**



**Figure 1-2: TK-3g Overall View**

## 2. Operation

---

### 2.1 General

Both the TK-3e and the TK-3g are self-contained and require only the appropriate power source connections for operation. To prevent circuit damage in the TK-3e, make sure to set the 115/230 VAC select switch to the proper position before connecting the unit to a power source.

#### **APPLICATION ADVISORY**

The TK-3e is supplied with a 120 VAC power cord. If you use a 240 VAC line voltage to power the instrument, you must use an alternate cord. To ensure safe operation, the power cord shall be a certified type with a 6A to 15A configuration attachment plug.

Both versions of the test kit have two universal probe holders called V Probe Mounts. The design of V Probe Mount permits you to properly position probes with different diameters in the Swing Arm and Spindle Micrometer assemblies.

The Wobble Plate generates a mechanical vibration reference for use as the input to the proximity probe. You control the vibration level that the probe sees by manually positioning the Swing Arm Assembly. Setting the assembly closer to the center of the Wobble Plate produces a smaller vibration amplitude, while moving it towards the Wobble Plate edge results in a larger vibration amplitude. Because the angle of viewed surface of the Wobble Plate is not 90° to the

proximity probe and the motor shaft, the probe observes a change in gap as the motor rotates the shaft and Wobble Plate.

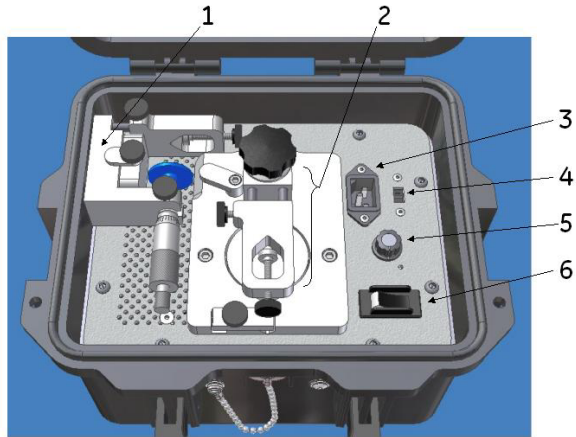

1. Spindle Micrometer Assembly
2. Swing Arm Assembly
3. Power inlet plug
4. Voltage Selector Switch
5. Speed Control knob
6. Power Switch

**Figure 2-1: TK-3e Key Components**

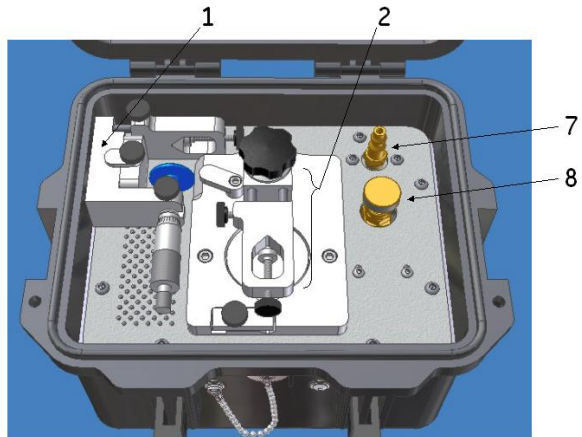

1. Spindle Micrometer Assembly
2. Swing Arm Assembly
7. Air Inlet barb
8. Speed Control Valve knob

**Figure 2-2: TK-3g Key Components**

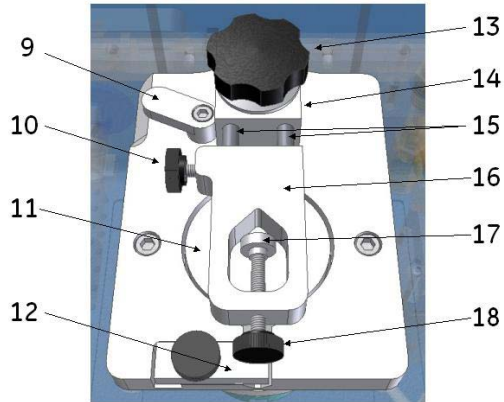

- 9. Stop Cam
- 10. Side thumbscrew
- 11. Wobble Plate
- 12. Keyphasor Probe Clamp
- 13. Large rosette knob
- 14. Swing Arm Base
- 15. Dowel pins
- 16. V Probe Mount
- 17. Probe Clamp Tip
- 18. Probe Clamp thumbscrew

**Figure 2-3: TK-3 Top Plate Key Components**

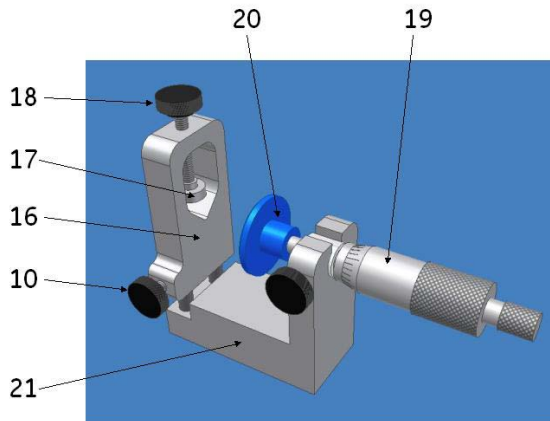

- 10. Side thumbscrew
- 16. V Probe Mount
- 17. Probe Clamp Tip
- 18. Probe Clamp thumbscrew
- 19. Spindle Micrometer
- 20. Button Target
- 21. Spindle Micrometer Assembly base

**Figure 2-4: Spindle Micrometer Mount Key Components**

### 2.1.1 Spindle Micrometer Operation

The Spindle Micrometer Mount Assembly consists of a Spindle Micrometer with an attached Button Target, a Magnetic-Base Spindle Micrometer Mount, and a V Probe Mount. Adjust the V Probe Mount axial position by loosening the side thumbscrew and sliding the V Probe Mount axially along the dowel pins. Fix the axial position by tightening the side thumbscrew.

## NOTE

Care should be taken to always keep the side thumbscrew of the V Probe Mount tightened in order to avoid accidental loss of the V Probe Mount during transport and use.

The Spindle Micrometer Mount Assembly is equipped with a flush-mounted, shielded magnet, housed in its base. This feature is provided to aid in field use of the unit. Attaching the Spindle Micrometer Mount Assembly to a machine case or other ferrous metal object frees up one of the user's hands that would normally support the assembly during calibration procedures. Take care to not put the Spindle Micrometer Mount Assembly too close to magnetic data storage devices or computer monitors, as the magnet may adversely affect their function. Do not bring the magnet into direct contact with either the Button Target or the Wobble Plate. Magnetization of these target materials will degrade their performance.

### **To Install A Probe Into The Spindle Micrometer Mount Assembly**

1. Set the spindle micrometer to the "zero" position.
2. Set the V Probe Mount to the bottom of its adjustment and tighten the V Probe Mount side thumbscrew snugly.

3. Install the probe into the V Probe Mount by sliding it through until the probe face and target face are butted up flush with one another. Take care not to damage the probe tip; insertion with excessive force is not necessary. See Figure 2-5 for reference.

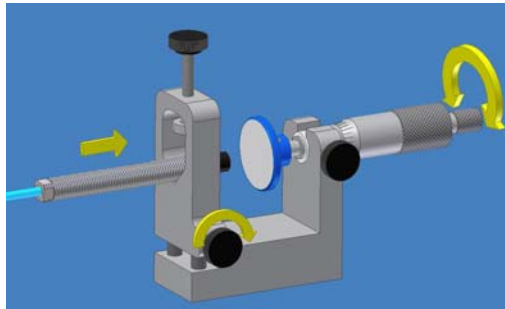

**Figure 2-5: Slide the probe through V Probe Mount until the Probe and Target faces are flush.**

4. Tighten the V Probe Mount Probe-Clamp tip (see Figure 2-6) until the clamp holds the probe snugly in place.

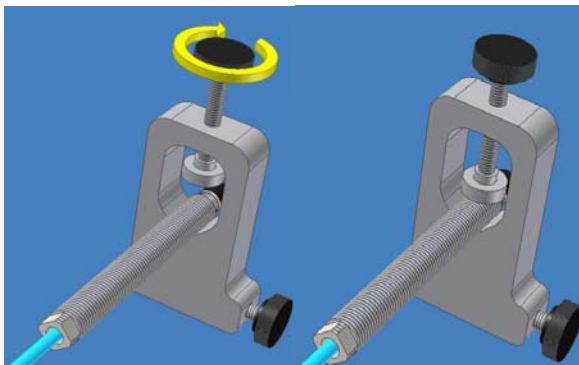

**Figure 2-6: Clamp Probe by Rotating Thumbscrew**

5. Set the probe/target alignment by adjusting the V Probe Mount such that the probe and target centerlines align (see Figure 2-7).

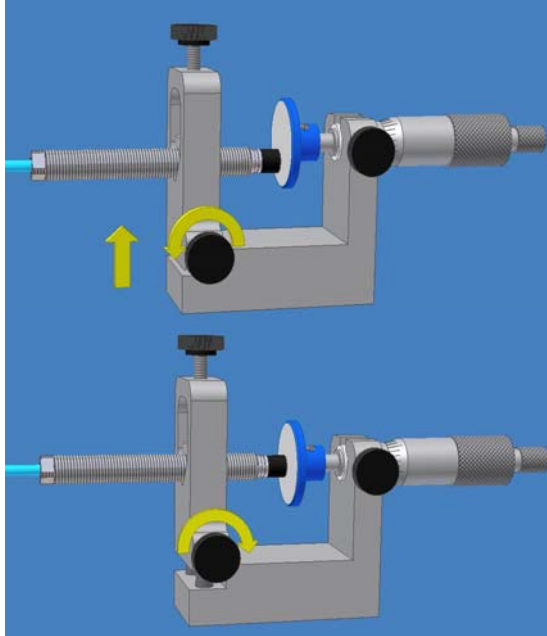

**Figure 2-7: 8mm Probe Adjusted to Centered Position**

### **2.1.2 Swing Arm Assembly Operation**

The Swing Arm Assembly consists of a Swing Arm Spindle, a Swing Arm Base, and a V Probe Mount.

You can adjust the V Probe Mount position both axially along the dowel pins of the Swing Arm Base, and radially about the Swing Arm Spindle. Adjust the V Probe Mount axial position by loosening the side thumbscrew and sliding the V Probe Mount axially along the dowel pins. Fix the axial position by tightening

the side thumbscrew. Please refer to Figure 2-8 for operation details.

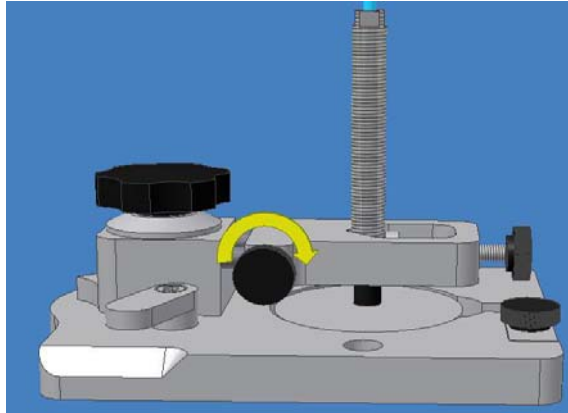

**Figure 2-8: 8mm Probe Fixed at Centered Position**

Adjust the V Probe Mount Radial position by first loosening the large rosette knob atop the Swing Arm Base and then pivoting the Swing Arm Assembly about the Swing Arm Spindle. Tightening the large rosette knob will fix the radial position. Please refer to Figure 2-9 for operation details.

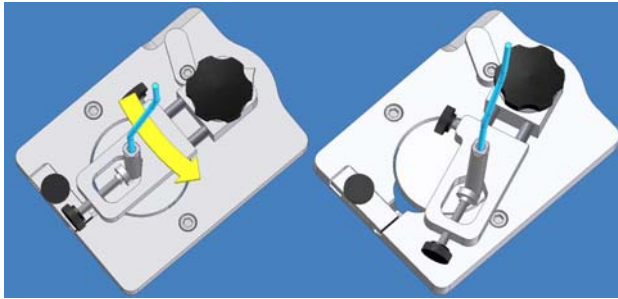

**Figure 2-9: 8mm Probe Position Adjusted For Large Amplitude Vibration**

The procedure to install a proximity probe is the same as that for the Spindle Micrometer Mount assembly, except that you must set the Probe/Wobble Plate gap before tightening the Probe Clamp to fix the Probe position. (See Section 4.3, RV Monitor Check for gapping specifics).

### NOTE

The TK-3 design incorporates redundant features. Should you damage the V Probe Mount of either the Spindle Micrometer Assembly or the Swing Arm Assembly, you can use the V Probe Mount from the alternate assembly in its place. Also note that all thumbscrews (except for that of the Keyphasor clamp, which is longer) are interchangeable.

### 2.1.3 Stop Cam

The Stop Cam located to the left of the Swing Arm assembly acts as a positive stop for the Swing Arm Assembly when you are adjusting the assembly to view minimum motion of the Wobble Plate. The Stop Cam position is set at the factory. Should it require re-adjustment, follow the steps listed in 3.1, General Maintenance to realign it.

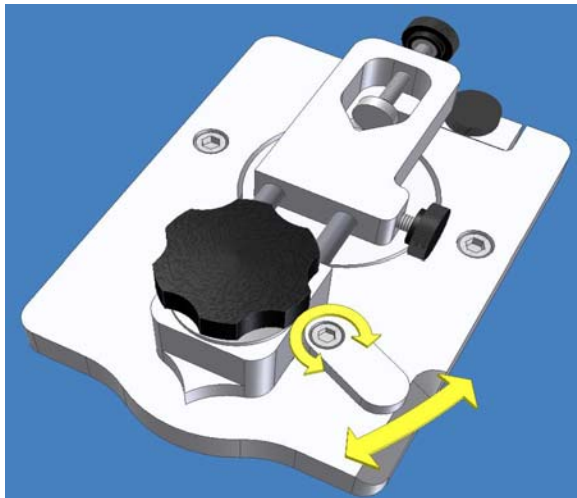

**Figure 2-10: Functionality of the Stop Cam**

### 2.1.4 Keyphasor Input Operation

The Keyphasor Input consists of a Keyphasor Hole Plug, a Keyphasor Access Hole, a Keyphasor Clamp, and a Keyphasor Clamp thumbscrew. The Keyphasor Plug covers the Keyphasor Access hole when the Keyphasor Input is not in use. The Keyphasor Access Hole allows the user to insert a Keyphasor probe through the TK-3 case to view the notched-edge of the Wobble Plate. Tightening the

Keyphasor Clamp thumbscrew fixes the Keyphasor probe in place.

### Checking Operation of the Keyphasor Input

1. Remove the Keyphasor plug from the case.
2. Loosen the thumbscrew on the Keyphasor Clamp (Figure 2-11), and press down on the left side to lift the Keyphasor Clamp to allow insertion of the Keyphasor probe through the unplugged hole.

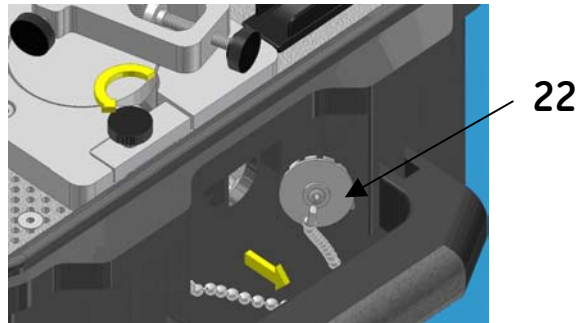

22. Keyphasor plug

### Figure 2-11: Remove Keyphasor Plug

3. Insert the Keyphasor probe to the appropriate gap position, per section 4.6 (Figure 2-12), and tighten the thumbscrew (Figure 2-13).

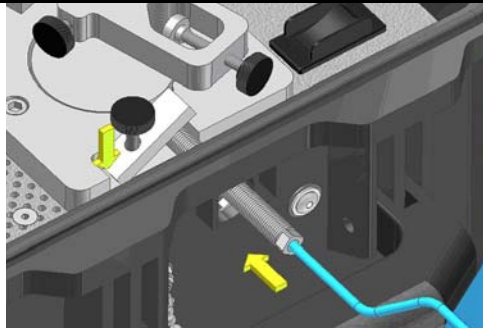

**Figure 2-12: Insert the Probe**

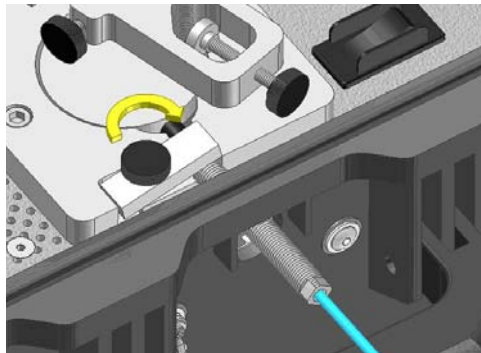

**Figure 2-13: Tighten the Thumbscrew**

## 2.2 Power-Up and Adjustment

For both models, setting the Speed Control at midrange each time the unit is used prolongs the life of the unit while still providing a vibration reference observable by vibration monitors. Vibration output remains constant across the entire speed range. As a result, Wobble Plate speed has very little effect on the amplitude of a vibration signal.

### 2.2.1 TK-3e

#### CAUTION

Rotating machinery present. Injury can result from flying debris or contact with moving parts. Always wear safety glasses and keep clear of the wobble plate when operating either the TK-3e or TK-3g.

The TK-3e motor drive is electrically powered. The drive system consists of a Power Plug, a Power Plug input, a Voltage Selector Switch, a Speed Control knob, and a Power Switch. The system will operate on either 115 VAC and 230 VAC, 50 and 60 Hz. You MUST set the Voltage Selector Switch to the right of the Power Plug input to the appropriate voltage setting prior to operating the unit to avoid damaging the TK-3e. The Speed Control knob varies the rotational speed of the Wobble Plate, and the Power Switch turns the unit ON or OFF.

To power the TK-3e up, first turn the Speed Control knob fully *counterclockwise* before turning the Power Switch to the ON position (see Figure 2-14). Once power is applied, turn the Speed Control knob *clockwise* to obtain the desired operating speed.

**NOTE**

The TK-3e is equipped with a magnetic-type circuit breaker ON/OFF switch, rated at 2.5A. If conditions trigger the circuit breaking mechanism within the switch, *immediately* unplug the unit from the external power source to reset the circuit breaker. Inspect the power cord and source for damage. If the unit will not run, and you have eliminated all external sources as possible causes, return the unit to Product Repair for maintenance at the earliest convenience.

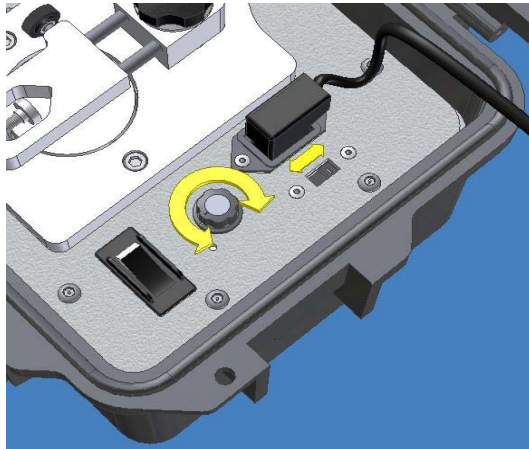

**Figure 2-14: Speed Control Knob for TK-3e Speed Adjustment, and Voltage Selection Switch**

### 2.2.2 TK-3g

The TK-3g motor drive is pneumatically powered. The drive system consists of a 1/4-inch Air Inlet barb fitting, and a Speed Control Valve knob. The system is designed to run with air supply pressures ranging from

40psig to 90psig. The Speed Control Valve knob varies the rotational speed of the Wobble Plate.

To power the TK-3g up, first turn the Speed Control fully *clockwise* before attaching the air hose to the intake fitting (see Figure 2-15). After the air hose is attached, turn the Speed Control *counterclockwise* to obtain the desired operating speed.

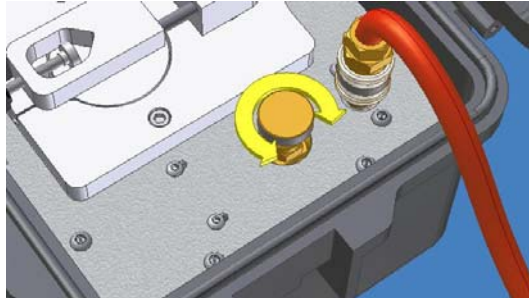

**Figure 2-15: Speed Control Knob for TK-3g Speed Adjustment**

### **NOTE**

The TK-3g is equipped with a pressure relief valve set to discharge excess pressure above 100psig. Should you hear a hissing noise within the unit immediately after connecting to the air supply with the Speed Control valve turned completely *clockwise*, the pressure relief valve has been triggered. In this event you must install an in-line pressure regulator set to no more than 90psig before the TK-3g unit. If the hissing persists, the internal air supply line may be damaged, and you should return the unit to Product Repair for maintenance at the earliest convenience.

---

## 2.3 Observed Material Substitution

If a material other than 4140 steel is to be observed by the probe, then the Wobble Plate must be changed and the spindle micrometer target must be altered to ensure proper testing and calibration.

To alter the spindle micrometer target material, fabricate a substitute target disc from the same material (e.g., brass, copper, aluminum) that the probe will observe. The substitute target disc should be 1.20 inches (30.48 mm) in diameter, and at least 0.125 inches thick. The surface finish of the viewed target face should be 63  $\mu$ -inches RMS, or better. Glue the substitute target disc to the face of the 4140 steel target.

To install a substitute Wobble Plate, follow the instructions below. The substitute Wobble Plate must be the same size as the standard Wobble Plate, and must be properly balanced. See your sales representative to order a substitute wobble plate made from a special material.

1. Remove the snap-in Keyphasor Hole Plug from the 7/8-inch (22.2 mm) opening on the front side of the instrument case (see Figure 2-16). The wobble plate is secured to the motor shaft by two setscrews with a 3/32-inch hexagonal (Allen) head (see Figure 2-17).

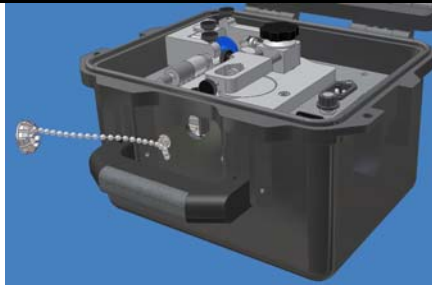

**Figure 2-16: Remove the Keyphasor Plug**

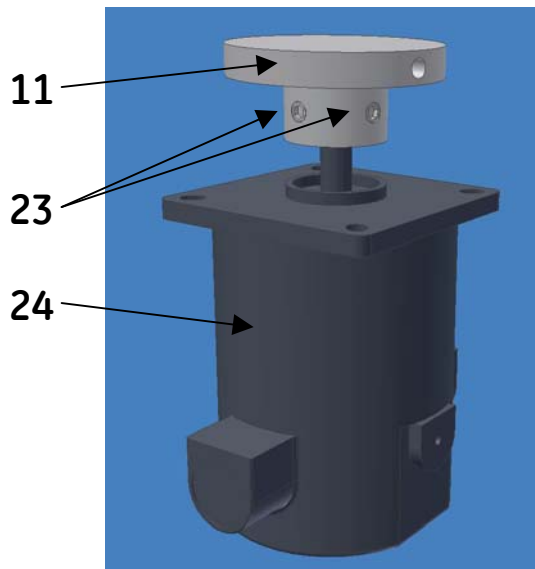

**Figure 2-17: Wobble Plate Secured by Two Setscrews**

- 23. Set Screws
- 24. Drive Motor
- 11. Wobble Plate

2. Loosen the side-mounted thumbscrew of the V Probe Mount attached to the Swing Arm Assembly. Remove the V Probe Mount from the assembly, and set it aside (see Figure 2-18).

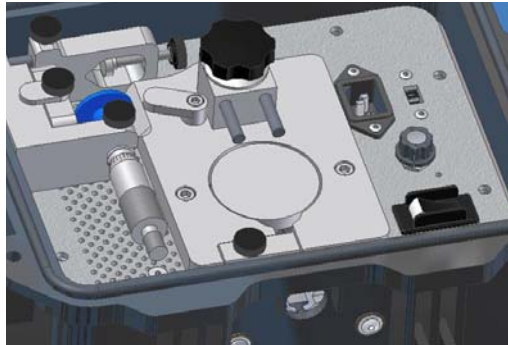

**Figure 2-18: Remove the V Probe Mount**

3. Rotate the Wobble Plate until the Keyphasor notch in the side of the Wobble Plate is aligned with the Keyphasor Access Plate is aligned with the Keyphasor Access Hole (see Figure 2-19). The first setscrew will now be aligned with the Keyphasor Access Hole, as well (see Figure 2-20).

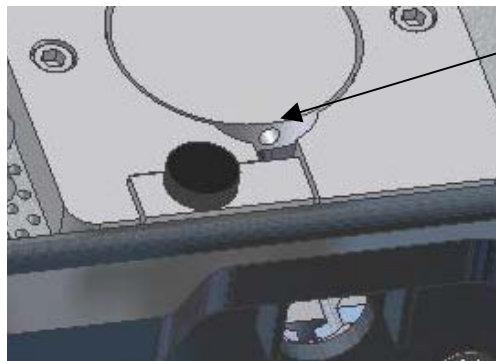

25

25. Keyphasor notch

**Figure 2-19: Keyphasor Notch Aligned with the Keyphasor Access Hole**

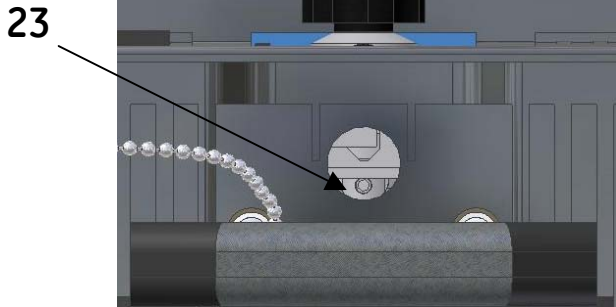

23. Set Screw

**Figure 2-20: First Setscrew Aligned with the Opening**

4. Use a 3/32-inch Allen wrench to loosen the setscrew (see Figure 2-21). To view the setscrew, you may need to position the instrument case so that surrounding light can shine through the opening. You can also use a flashlight.

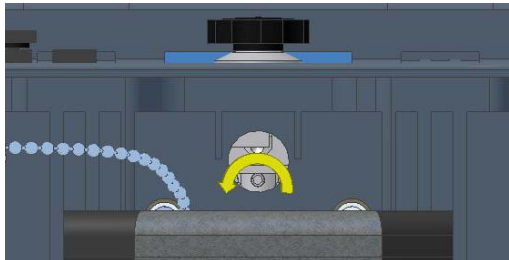

**Figure 2-21: Loosen the Setscrew**

5. Rotate the Wobble Plate 1/4 turn clockwise and loosen the second setscrew.
6. When the setscrews are loosened, remove the Allen wrench. Carefully insert a small

screwdriver through the same access hole below the hub of the Wobble Plate.

7. Rotate the Wobble Plate in small increments, while carefully exerting downward pressure on the screwdriver handle to lift the Wobble Plate off.

To provide vertical clearance between the Swing Arm Base dowel pins and the Wobble plate during Wobble Plate removal, you may need to loosen the large rosette knob, atop the Swing Arm assembly, and slide the Swing Arm Base up along its spindle (Figure 2-22).

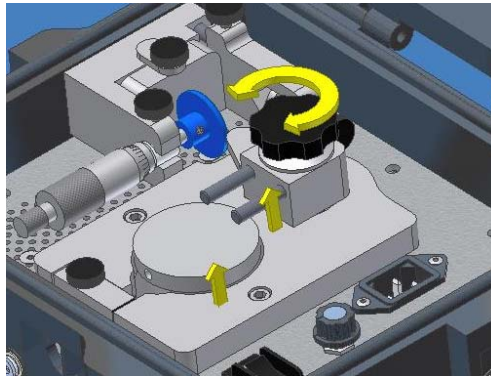

**Figure 2-22: Lift the Wobble Plate off**

8. Place the substitute Wobble Plate over the shaft so that the Keyphasor notch is aligned with the flat on the shaft and the Keyphasor Access Hole in the case. Set the height of the Wobble Plate so that the Keyphasor notch on the side of the Wobble Plate is centered on the face of the Keyphasor probe to be checked. The high side of the Wobble Plate should be no higher than flush with the top surface of the Top Plate.

9. When you have properly positioned the substitute Wobble Plate tighten the first setscrew. Then rotate the Wobble Plate 1/4 turn clockwise and tighten the other setscrew.
10. Reinstall the Keyphasor Hole plug in the 7/8" Keyphasor Access Hole.
11. Reinstall the V Probe Mount onto the Swing Arm Assembly.
12. Re-tighten all thumbscrews.

## 3. Maintenance

---

### 3.1 General Maintenance

Periodic cleaning of the case and components is necessary for the continued operation and reliability of the unit. Clean the case inner and outer surfaces with a water-damp cloth. To minimize corrosion, clean all exposed metal parts with WD-40 or lightweight oil. Users should also oil the Wobble Plate because corrosion on its viewed surface can affect the accuracy of the observing probe's measurements, resulting in false inputs to an associated monitoring system.

The bearings of both the TK-3e and TK-3g have been lubricated for the life of their respective motors and do not require oiling.

### 3.2 Wobble Plate

#### 3.2.1 Stop Cam Adjustment

Perform the following steps in the order given to establish the Wobble Plate minimum motion level. This procedure will reveal bearing problems.

#### **APPLICATION ALERT**

Before removing the probe from the machinery, be sure to disconnect the probe lead from the extension cable. Reconnect the probe to the extension cable after the probe is inserted in the Swing Arm Assembly. This will prevent probe lead and cable damage caused by twisting during removal.

See Table 3-1 for test equipment requirements. Connect the probe and test equipment to the Proximitor sensor as shown in

**Table 3-1: Recommended Maintenance Equipment**

Item	Minimum Specification	Suggested Equipment
Digital multimeter, 4-1/2 digits	1 M $\Omega$ input impedance ac volts to 100 Vac dc volts to 100 Vdc dc current to 200 mA-dc Resistance to 1 M $\Omega$	HP 3465A/B (DMM)
Oscilloscope	10 Vpk-pk dc to 1 Mhz bandwidth	Tektronix Model 5110
Power supply	-18Vdc or -24Vdc output, depending on Proximitor used, capable of 30 mA minimum output current	Bently Nevada
Probes, extension cables	Appropriate units to be used with Proximitor sensor	Bently Nevada

1. Carefully position the probe in the Swing Arm Assembly, above the Wobble Plate. Adjust the probe gap to equal the probe gap in the monitored machine (refer to the appropriate probe calibration graph to determine the gap) (See Section 4.2, General Description). And, tighten the Probe Clamp tip. The probe gap can be

adjusted using a feeler gauge or by observing the Proximitor DC output on a digital multimeter, and referring to the appropriate calibration graph. Do not tighten the probe clamp more than necessary to hold the probe.

2. Position the swing arm to minimize peak-to-peak vibration as indicated on the oscilloscope display.
  - a. Adjust the Speed Control to midrange and set the power switch to ON (TK-3e), or rotate the Speed Control Valve knob 2 full turns *counterclockwise* (TK-3g).
  - b. Adjust the large rosette knob atop the Swing Arm Base so that it moves with low resistance.
  - c. Use a 5/32-inch Allen wrench, to loosen the cap screw inside the Stop Cam. Loosen the screw just enough so that it can rotate to a position where the handle points directly at the back of the case.
  - d. Loosen the side adjustment screw just enough to allow movement of the V Probe Mount along the dowel pins.
  - e. Slowly adjust the axial position of the V Probe Mount and the radial position of the Swing Arm Assembly. Observe the oscilloscope during this adjustment.
  - f. Once you have found the point of minimum movement, tighten the side adjustment thumbscrew of the V Probe Mount, and the large rosette knob of the Swing Arm Assembly to fix

the Swing Arm Assembly in this position.

- g. Pivot the Stop Cam arm counterclockwise until the cam feature makes contact with the side of the Swing Arm assembly.
- h. Gently re-tighten the cap screw within the Stop Cam. Excessive torque is not required as it may damage the plastic washer under the head of the cap screw. The Stop Cam needs only to be snug enough to prevent the Swing Arm Assembly from rotating *clockwise* past the minimum vibration amplitude position.
- i. Gradually increase the wobble plate Speed Control to its maximum setting. The deflection on the oscilloscope display should not vary with a change in wobble plate rpm. A deflection on the display of more than 0.2 mil (0.005 mm) means the unit has faulty bearings and should be returned to Bently Nevada Product Repair for maintenance.

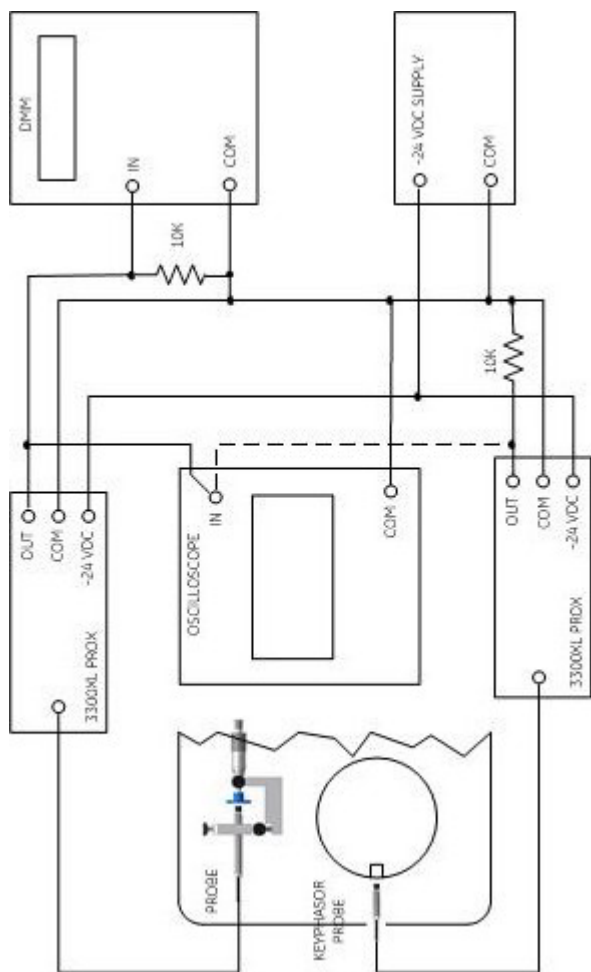

Figure 3-1: Equipment Set-up

## 4. Calibration

---

### 4.1 General

This section includes the procedures to help the user check thrust and radial vibration channel operation. In addition, this section contains a procedure for determining the Keyphasor probe gap and checking the transducer system operation.

### 4.2 Transducer System Check

The Proximator unit must be connected to the probe and its associated extension cable. The procedure must use a target with the same or of similar electrical properties as the observed material in the monitored machinery. The recommended maintenance equipment for performing the procedures in this section is given in Table 3-1. The test equipment setup is shown in Figure 3-1.

Successful completion of the following procedure will test the transducer system operation. The steps should be performed in the order given.

1. With the spindle micrometer set to zero, position the probe into the Spindle Micrometer Mount so that the probe tip lightly contacts the observed sample. Center and secure the probe in position. Adjust the spindle micrometer so that the sample moves away from the probe tip, and then return it to zero to ensure the probe is positioned properly.
2. Connect the probe to the Proximator using the appropriate extension cable.

3. With input power disconnected, connect the power supply minus (-) output to the Proximator -18Vdc or -24Vdc input, whichever is applicable. Connect the power supply common terminal to the Proximator COM connector.
4. Connect the DMM between the Proximator SIG and COM connectors. Connect a 10k ohm resistor across the DMM input terminals.
5. Energize the power supply, and adjust the spindle micrometer for the probe gap appropriate for the probe in use. (If in doubt, refer to the technical manual for the equipment using that probe.)
6. Adjust the spindle micrometer 10 more mils (0.25 mm) away from the probe face. The DMM should indicate approximately 2 volts more for a 200 mV per mil (7.87 V/mm) scale factor, or approximately 1 volt more for a 100 mV per mil (3.94 V/mm) scale factor.
7. Draw probe voltage vs. gap graph using graph paper graduated in 1-inch or 1-cm increments. Divide the vertical scale into increments of 2 volts per division, and the horizontal scale into increments of 10 mils (0.25 mm) per division. Begin from the graph zero point with the probe gap set at zero. Slowly adjust the spindle micrometer to increase the probe gap distance, and plot the voltage change over a range of increasing gap settings.

---

**APPLICATION ADVISORY**

The first 10 or 20 mils (0.25 mm or 0.50 mm) of the curve cannot be used due to probe nonlinearity. A sharp change in the slope of the curve will occur at a probe-to-target gap of about 10 to 20 mils (0.25 mm to 0.50 mm). This change will depend upon the type of probe and Proximitor sensor used and the type of material being observed. The response curve should be linear from 20 mils (0.50 mm) to 50 to 100 mils (1.27 mm to 2.54 mm) or more. Continue plotting the voltage vs. gap graph until the linear response starts to become nonlinear. You should keep the completed graph for future reference. Consult the appropriate transducer manual for further transducer performance and Proximitor recalibration information on the particular transducer system in use.

8. If you have completed all the preceding steps successfully, you have verified the transducer system operation for a particular combination of probe, extension cable, Proximitor, and observed material. However, any time that a different type of target material is observed, or a major change occurs to the probe, Proximitor, or cable, you should check the transducer system operation again.

### 4.3 RV Monitor Check

There are two methods of RV monitor testing. This section presents these methods in order of preference.

1. The calibration procedure found in the applicable RV monitor manual is the preferred method. This method uses a signal generator to provide a precision

simulated vibration waveform and an oscilloscope or DMM to determine the waveform amplitude. The accuracy of this method is approximately 1 to 2%.

2. Using the TK-3 Wobble Plate, a transducer system to provide a vibration waveform for checking monitor calibration, and an oscilloscope to determine the waveform amplitude is an alternate method. An oscilloscope is preferred over a DMM for measuring the peak-to-peak amplitude as this will help to eliminate errors due to possible waveform distortion. The accuracy of this method is approximately 3 to 4%. The use of a DMM to perform this measurement is acceptable, but will reduce the accuracy approximately 5 to 10%.

#### 4.4 TK-3 Monitor RV Calibration Check

If a signal generator is not available, using a TK-3 with an oscilloscope is an alternate means of checking the calibration of an RV monitor.

<b>NOTE</b>
The following procedure is for the TK-3e but it can be performed with either unit.

1. Insert the probe into the V Probe Mount. Adjust the probe gap using one of following three ways:
  - using a feeler gauge (mechanically),
  - observing the dc voltage on a DMM (electrically), or
  - using the gap switch on the monitor to be checked.

The gap used for this test must equal the normal probe gap as installed in the monitored machine. To determine the gap, refer to the appropriate transducer voltage vs. gap graph or the Application Note for gapping RV proximity transducers. When removing the probe from the equipment, always disconnect the probe lead from the extension cable first. Tighten the Probe Clamp tip of the V Probe Mount after the proper probe gap is set.

2. Connect the probe and its extension cable to the Proximator sensor using an appropriate length of extension cable and the Proximator sensor to the monitor. The appropriate Proximator or monitor manuals provide the connection procedures. Refer to either or both of these manuals if the connections have not already been made.
3. Energize the monitoring system.
4. The monitor OK light should now be illuminated to indicate that the probe gap is within the proper operating range, the proper voltage is being applied to the system, and all connections are secure. If the monitor OK light does not illuminate,

check the appropriate monitor manual for the troubleshooting procedure.

5. Set the ON/OFF switch to OFF, the power input controls to the proper voltage (115 Vac or 230 Vac), and connect the power source. Set the Wobble Plate Speed Control to the lowest position, switch the power on, and bring speed to midrange or a value within the passband of the monitor.
6. Use the oscilloscope to adjust the position of the probe over the Wobble Plate to obtain a peak-to-peak voltage, which is equal to the full-scale reading of the monitor. Divide the peak-to-peak voltage by 0.2 V/mil (7.87 V/mm) for 7200 and most 3000 and 3300XL Series transducers, or by 0.1 V/mil (3.94 V/mm) for 7000 Series transducers to obtain the equivalent meter reading in mils. If an oscilloscope is not available, you may use the DC voltage output of the Proximity probe to obtain an indication of the equivalent peak-to-peak voltage, which the transducer system outputs to the monitor.
7. The monitor meter should indicate a peak-to-peak vibration in mils that is approximately equal to the equivalent meter reading as measured by the oscilloscope in the preceding step.
8. If the monitor meter reading and the oscilloscope equivalent reading are approximately the same, monitor recalibration is neither required nor recommended as the monitors have been calibrated as accurately as possible before shipping. If the oscilloscope value and monitor meter reading are not within

reasonable agreement, refer to the appropriate monitor manual for proper adjustment.

## 4.5 Thrust Monitor Check

The spindle micrometer generates a precise gap reference. Using the same setup for checking the transducer operation (see Transducer System Check in Section 4.2) you may use the spindle micrometer to simulate the appropriate “zero” gap and the appropriate “normal” and “counter” thrust motions to either side of the zero gap. Refer to the appropriate thrust monitor manual if any adjustments are required.

## 4.6 KPH Probe Gap Determination

You should use the following procedure to determine the optimum gap between a Keyphasor probe and the observed surface.

1. Connect the test equipment as shown in Figure 3-1. However, connect the Keyphasor Proximitors OUT signal, rather than the Proximitors OUT signal, to the oscilloscope IN.
2. Insert the probe to be used into the Keyphasor mounting slot, and clamp down the probe. When inserting the probe into the Keyphasor mounting slot, loosen the Keyphasor Clamp thumbscrew and apply pressure to clamp, the left of the thumbscrew, to rock to Keyphasor clamp open.

3. Energize the Wobble Plate and adjust to any desired speed, preferably midrange (refer to Section 3.2, Wobble Plate).
4. With power applied to the Proximitor sensor, use the oscilloscope to manually adjust the probe toward and away from the wobble plate edge to a point at which the optimum voltage excursion (spike) is displayed.
5. Carefully secure the probe in place by tightening the Keyphasor Clamp. Make sure that the displayed voltage excursion remains unchanged. If it has changed, readjust the probe as necessary.
6. Turn off the Wobble Plate.
7. Using a feeler gauge, measure the gap between the probe tip and the wobble plate edge. For optimum performance, the measured gap should equal the one between the monitored rotor shaft and the installed probe tip.

## 5. Specifications

---

### 5.1 Power

#### 5.1.1 TK-3e



#### APPLICATION ALERT

2-Position Voltage Input Selector Switch. Damage to the unit can occur if the Voltage Selector Switch is not set to the appropriate voltage input position.

95 to 125 Vac, 50 to 60 Hz, 1 A max.

190 to 250 Vac, 50 to 60 Hz, 1 A max.

#### 5.1.2 TK-3g

40 to 90 PSI @ 15 std cfm max ( $2.76 \times 10^5$  to  $6.21 \times 10^5$  N/M<sup>2</sup> @ 26 std cubic meters per hour)

### 5.2 Housing

Impact-resistant resin carrying case.

### 5.3 Dimensions (overall)

Height: 195 mm (7.7 inches)

Width: 248 mm (9.8 inches)

Length: 299 mm (11.8 inches)

## **5.4 Controls**

Wobble Plate Speed

Vibration Amplitude

ON/OFF (TK-3e)

## **5.5 Target Material**

4140 steel

## **5.6 Wobble Plate**

### **5.6.1 TK-3e Rotational Speed**

5,000 rpm  $\pm$  1,000 rpm over the specified line voltage range.

### **5.6.2 TK-3g Rotational Speed**

5,000 rpm  $\pm$  1,000 rpm over the specified air supply line pressure and volumetric flow range.

### **5.6.3 Vibration Amplitude Range**

50 mm to 254 m (2 mils to 10 mils) peak-to-peak.

### **5.6.4 Target Button and Wobble Plate Interchangeability**

Less than 5% change in average scale factor.

## **5.7 Spindle Micrometer**

Range: 0 to 25 mm (0 to 1,000 mils)

## **5.8 Environmental**

### **5.8.1 Temperature Range Operational**

Min Temperature: 0°C (32°F)

Max Temperature: 54°C (130°F)

NOTE: Temporary operation below minimum temperature is acceptable.

### **5.8.2 Exposure**

Dust and Water Resistant (case lid closed)